

VEMAG Multi-Trayloader MTL280

Product distribution for minced meat and forming lines



Maximum flexibility for multiple-strand processing.

Do you run complex production lines? - Would you like to distribute your products over multiple strands? Do you pack products automatically? - Do you need an optimum solution for inserting your products in the direction of transport of your packing machine? Are you seeking a flexible solution you can use for all your products?

Put your confidence in VEMAG's Multi-Trayloader MTL280 and benefit from extremely accurate positioning and maximum transfer rates.



VEMAG Multi-Trayloader MTL280

Multi-Trayloader MTL280 supplements all single-strand VEMAG production lines.

Application

The Multi-Trayloader MTL280 can be used wherever products are portioned in single strands and then taken away in the direction of transport of the packing machine in multiple strands. It is perfectly straightforward to integrate in VEMAG production lines and is the ideal complement to forming machine FM250, minced meat portioner MMP220 and all VEMAG cutters.

Design

The base frame is made entirely of stainless steel. A transmission housing contains all the mechanical drive

elements. The shuttle conveyor is suspended on one side of the base frame and is driven from out of the transmission housing. The retracting edge is driven by a shaft which executes a linear movement. If the retracting edge travels 650 mm, the shuttle conveyor executes up to 40 strokes per minute.

The lateral discharge conveyor is permanently connected to the shuttle conveyor.

Handling

The Multi-Trayloader is simple to operate. The operator enters the parameters for depositing products using the integrated screen.

The Multi-Trayloader is suitable for cleaning with low-pressure equipment and is easily maintained.

All the benefits at a glance

- Simple integration in VEMAG production lines
- Can be used flexibly for all single-strand applications
- High transfer rates
- Accurate product positioning



www.vemag.de

Technical data

Belt width:	250 mm / 600 mm
Belt length:	1,800 mm
Travel of retracting edge:	650 mm
Distribution speed:	up to 40 strokes/min. / 12 strokes/min.
Can be combined with:	forming machine FM250 minced meat portioner MMP220 filling head 981 cutter 808 Coex 891 – 894

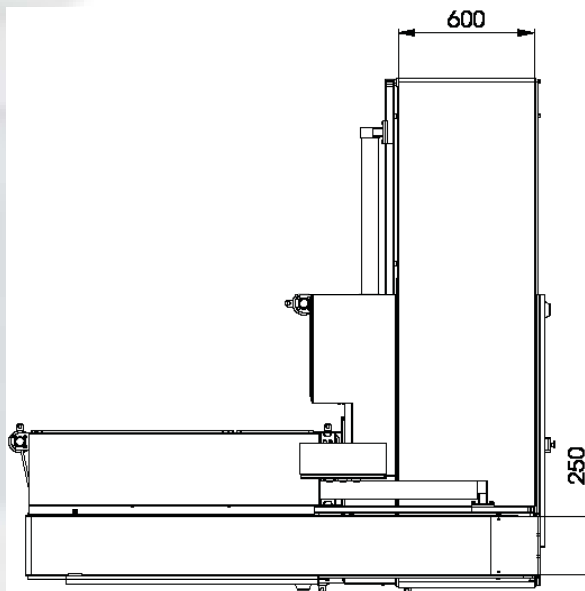
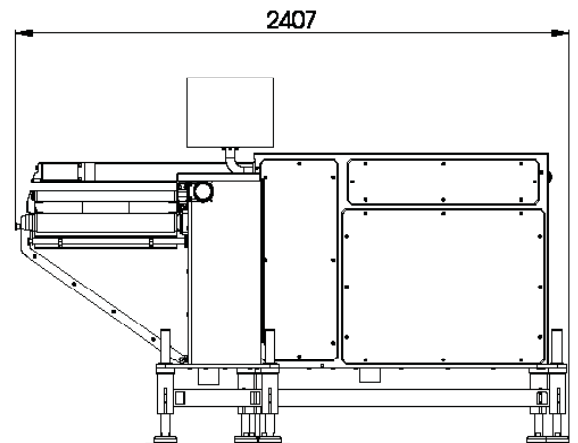
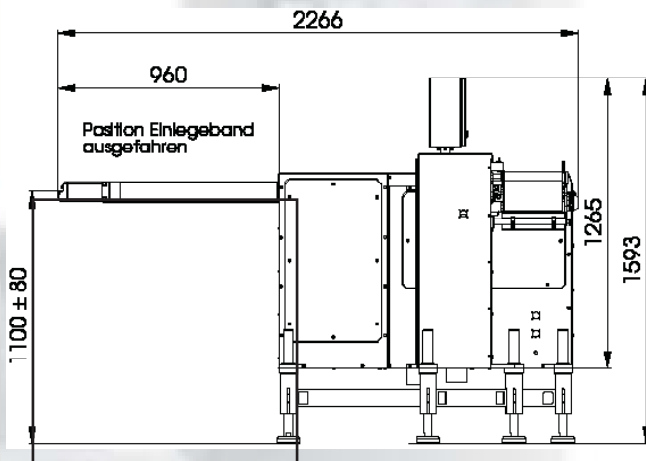

VEMAG Maschinenbau GmbH
 P.O. Box 1620, D-27266 Verden
 Phone +49 42 31 - 77 70, Fax +49 42 31 - 77 72 41
<http://www.vemag.de>, e-mail@vemag.de

Presented by: